

DO NOT SCALE DRAWING

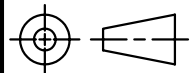

THIRD ANGLE PROJECTION

REVISIONS

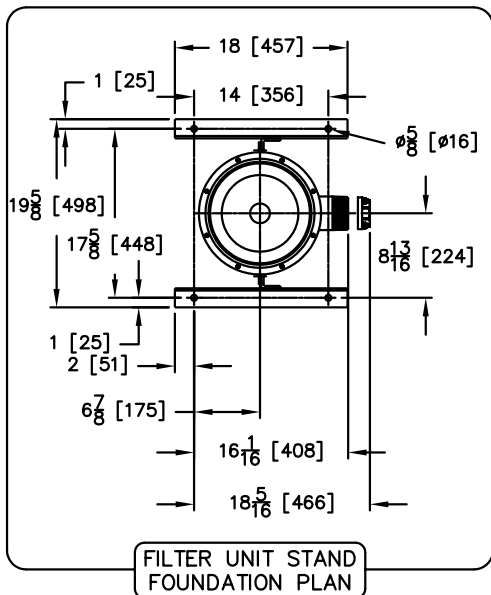

FILTER UNIT STAND FOUNDATION PLAN

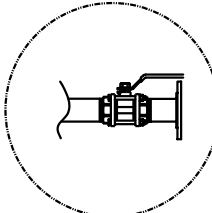

DETAIL 1: MANUAL PURGE VALVE

98 1/8 [2492]  
MINIMUM  
OVERHEAD  
CLEARANCE

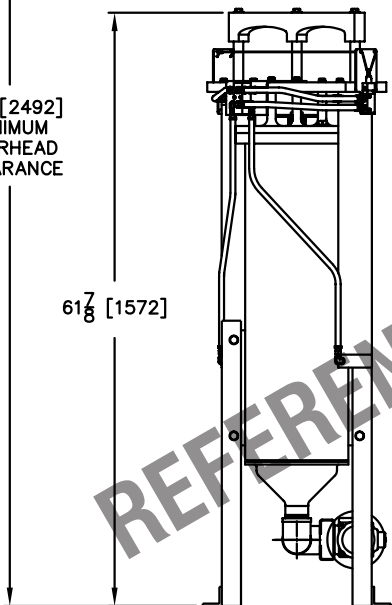

REFERENCE ONLY

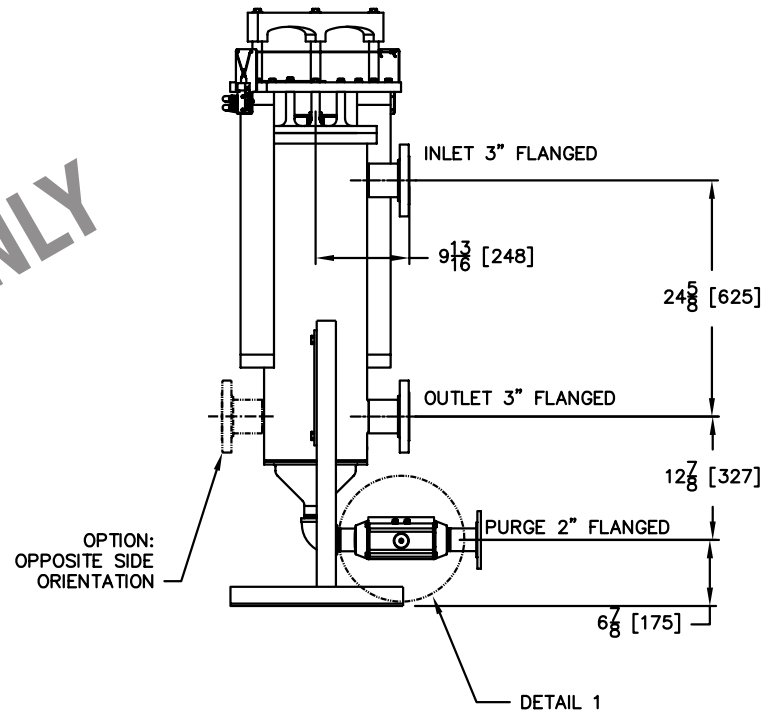

NOTES:

1. ALL DIMENSIONS SHOWN IN INCHES, WITH MILLIMETER EQUIVALENTS IN BRACKETS [ ].
2. FILTER ELEMENT IS DESIGNED TO WITHSTAND 110 PSID (7.58 BAR) DIFFERENTIAL PRESSURE.
3. DESIGN PRESSURE OF UNIT IS 150 PSI [10.34 BAR].
4. PROCESS FLANGE CONNECTIONS ARE DRILLED TO ANSI, CLASS 150, OR CUSTOMER SPECIFIED DIN EQUIVALENT. BODY TUBE IS MADE FROM 10" PIPE.
5. INLET AIR CONNECTION IS 1/4" NPTI. SUPPLY AIR IS TO BE CLEAN, DRY, NON-LUBRICATED AIR. 80 PSI MIN. [5.52 BAR] 120 PSI MAX. [8.27 BAR]



EATON FILTRATION, LLC  
RONNINGEN-PETTER PRODUCTS  
9151 SHAVER ROAD  
PORTAGE, MICHIGAN 49024-6798 USA

THIS DRAWING AND ALL INFORMATION THEREON IS THE PROPERTY OF EATON CORPORATION. IT IS CONFIDENTIAL AND MUST NOT BE MADE PUBLIC. THIS DRAWING IS LOANED SUBJECT TO RETURN ON DEMAND, AND IS NOT TO BE USED DIRECTLY OR INDIRECTLY, IN ANY WAY DETRIMENTAL TO THE INTERESTS OF EATON FILTRATION, LLC.

ENGINEERING APPROVAL .	DRAWN BY M. DESJARDINS	TITLE DCF-1600 SINGLE W/ TWIN ACTUATOR DESIGN UNIT DRAWING			
SALES/MKTG APPROVAL .	SCALE NONE				
ENGINEERING SPECIFICATION .	DATE 05/13/05	SIZE A	DWG FILENAME DCF-1600-TWSI-GA002	REV A	